

in[mm]

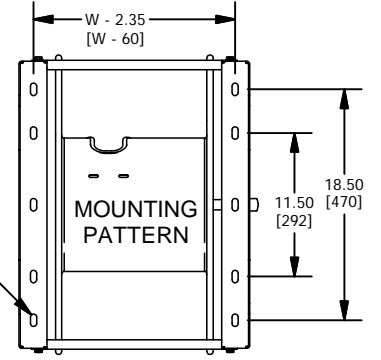
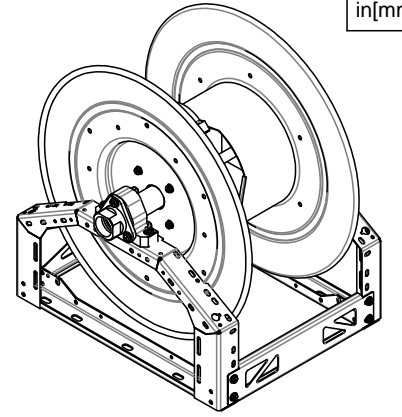
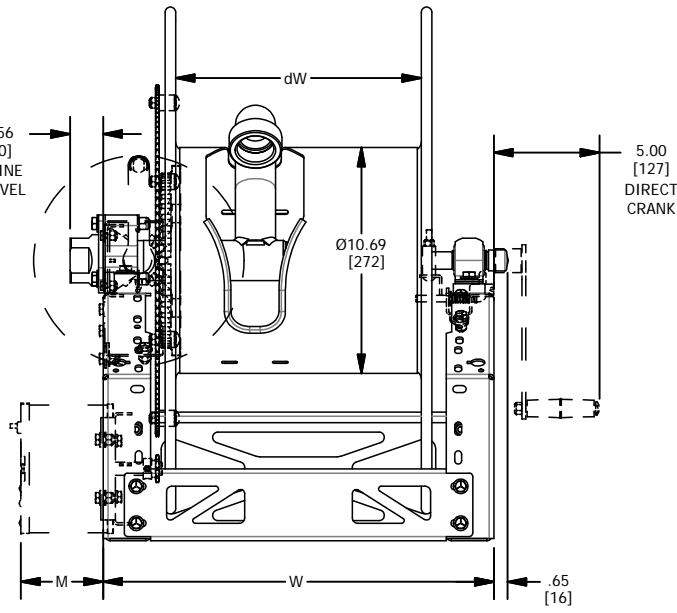
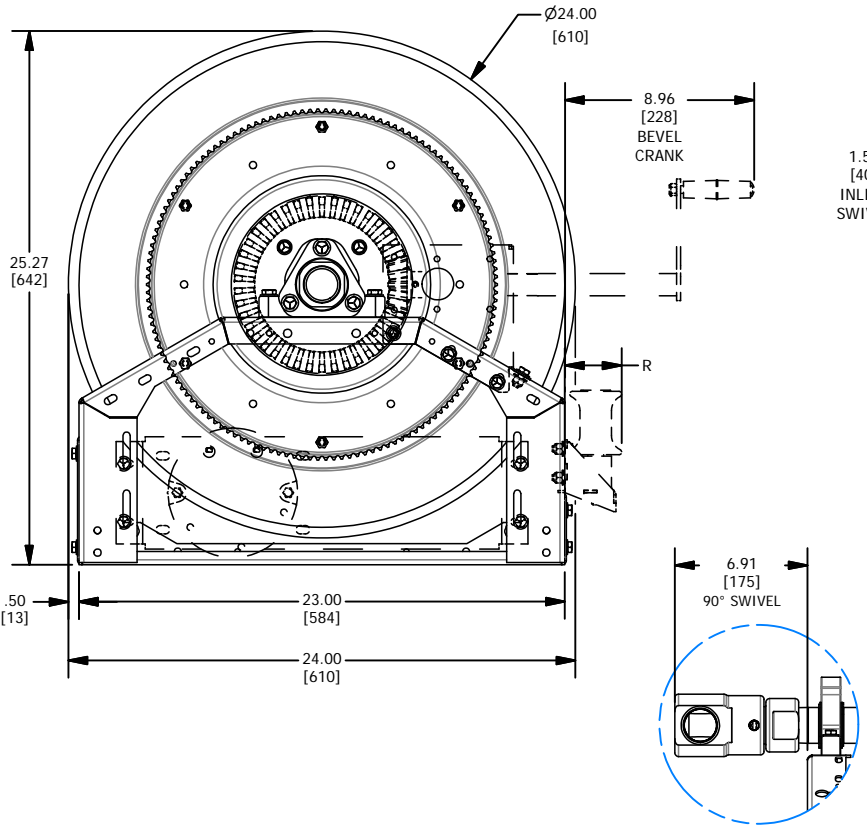

DIMENSION M in[mm]					DRIVE OPTIONS
MOTOR DRIVE SYSTEM	DIRECT DRIVE	+ IDLER GEAR	+ CLUTCH	+ IDLER & CLUTCH	
ELECTRIC MOTOR: 1/3 HP (12VDC, 24VDC)	4.25 [110]	5.00 [130]	4.25 [110]	5.00 [130]	IDLER GEAR 1:2, 1:3, 1:4 RATIO CENTRIFUGAL CLUTCH EXTERNAL SHAFT FOR BRAKES (ELECRO-MAG. OR 3-WAY BRAKE)
ELECTRIC MOTOR: 1/2 HP (12VDC, 24VDC, 115VAC, 230VAC)	6.00 [150]	6.88 [175]	6.88 [175]	7.88 [200]	
AIR MOTOR (4 VANE, ALUMINUM)	3.13 [80]	4.13 [105]	-	-	EXTERNAL SHAFT FOR BRAKES
AIR MOTOR (6 VANE, IRON)	4.75 [120]	-	-	-	-
HYDRAULIC	2.88 [75]	3.75 [95]	-	-	EXTERNAL SHAFT FOR BRAKES

DIMENSION R in[mm]	
ROLLER TYPE	DIM "R"
4-WAY ROLLERS	.82 [21]
UNIVERSAL 4-WAY ROLLERS	1.21 [31]
3-WAY ROLLERS	2.76 [70]
UNIVERSAL 3-WAY ROLLERS	3.15 [80]

MATERIAL SPECIFICATIONS		
COMPONENT	MATERIAL	OPTIONS
PLUMBING	ZINC PLATED STEEL	316 STAINLESS STEEL
SWIVEL	NI PLATED STEEL (INLINE)	316 STAINLESS STEEL INLINE OR 90°, 90° NI PLATED STEEL
SEALS	NITRILE	VITON, EPDM
REEL	STEEL	-
BEARINGS	BRONZE & TEFLON INFUSED PLATING	-
DRAG BRAKE	NYLON	BRAKE PAD MATERIAL
CHAIN GUARD	STEEL	ABS
FINISH	BLUE POWDER COAT	RED, GREEN, WHITE, BLACK, GREY

MODEL	dW in[mm]	W in[mm]	1.5" (2.06" OD) CAPACITY ft[m]	1.25" (1.81" OD) CAPACITY ft[m]	SHIPPING WEIGHT lb[kg]
1680-0824	8 [200]	15 [380]	35 [10]	50 [15]	72 [33]
1680-0924	9.5 [240]	16.5 [420]	45 [14]	60 [18]	74 [34]
1680-1124	11.5 [290]	18.5 [470]	60 [19]	75 [20]	77 [35]
1680-1324	13.5 [340]	20.5 [520]	70 [22]	85 [25]	80 [36]
1680-1524	15.5 [390]	22.5 [570]	75 [25]	100 [30]	83 [38]
1680-2024	20 [510]	27 [690]	100 [30]	130 [40]	89 [40]
1680-2224	22 [560]	29 [740]	125 [35]	145 [44]	92 [42]
1680-2424	24 [610]	31 [790]	140 [40]	155 [47]	95 [43]
1680-2524	25 [640]	32 [815]	150 [45]	160 [49]	97 [44]
1680-2824	28 [710]	35 [890]	165 [950]	175 [55]	102 [46]
1680-3324	33 [840]	40 [1020]	195 [60]	200 [60]	110 [50]

**PART NUMBER**

DRUM WIDTH — DISK SIZE — ROLLERS & SETUP

16 80 - 15 24 - XX - B X XX

PLUMBING SIZE: 60 = 1", 80 = 1.5"

MOTOR, CRANK & BRAKE OPTIONS

PLUMBING & SWIVEL OPTIONS

SPECIFICATIONS		OPTIONS
PRESSURE	1500 PSI [100 BAR]	3000 PSI [200 BAR]
TEMPERATURE	-40 F TO 275 F [-40 C TO 135 C]	-60 F [-50 C] EPDM 400F [240 C] VITON
INLET THREAD	1.5" NPT FEMALE	1.5" BSPT FEMALE
OUTLET THREAD	1.5" NPT FEMALE	1.5" NPT MALE, BSPP FEMALE, BSPT MALE, NST

**UNLISTED OPTIONS & CUSTOM REELS**

NOT ALL OPTIONS ARE LISTED, CONTACT YOUR SALES REPRESENTATIVE OR FACTORY FOR ADDITIONAL OPTIONS & CUSTOM MODIFICATIONS

**COXREELS**

5865 S Ash Avenue Tempe, Az 85283  
1-800-COX-REEL www.coxreels.com

THIS DOCUMENT CONTAINS PROPRIETARY INFORMATION AND IS THE PROPERTY OF COXREELS, INC. THE COPYING, DISTRIBUTION AND UTILIZATION OF THIS DOCUMENT AS WELL AS COMMUNICATION OF ITS CONTENT TO OTHERS WITHOUT THE WRITTEN AUTHORIZATION OF COXREELS, INC., IS PROHIBITED.

TITLE: **1600 SERIES, 24" DISK, 1.5" PLUMBING**

DWG. NO.: 1680-XX24

REV. B

3RD ANGLE

INTERPERT PER ASME : Y14.5M-1994 DO NOT SCALE DWG.

SIZE: A

SHT: 1 OF: 2

### ROLLER BRACKET OPTIONS

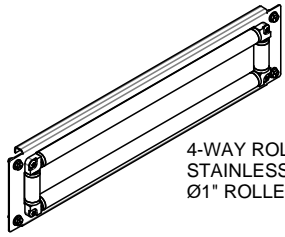

4-WAY ROLLERS  
STAINLESS STEEL  
Ø1" ROLLERS

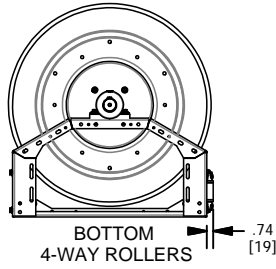

BOTTOM  
4-WAY ROLLERS

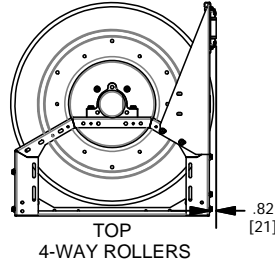

TOP  
4-WAY ROLLERS

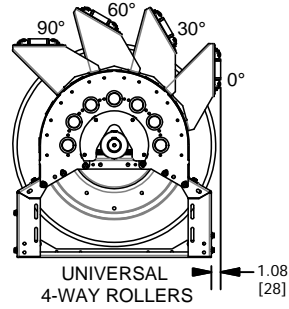

UNIVERSAL  
4-WAY ROLLERS

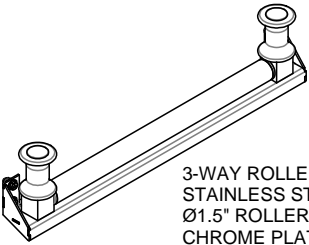

3-WAY ROLLERS  
STAINLESS STEEL  
Ø1.5" ROLLER  
CHROME PLATED  
STEEL SPOOLS

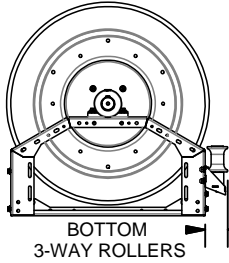

BOTTOM  
3-WAY ROLLERS

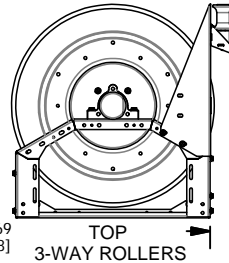

TOP  
3-WAY ROLLERS

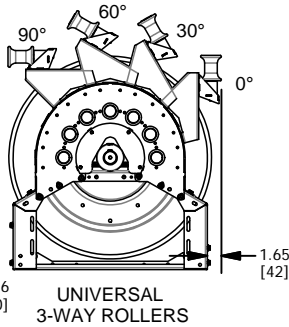

UNIVERSAL  
3-WAY ROLLERS

### BEVEL CRANK UNIVERSAL OPTION

UNIVERSAL BEVEL CRANK MOUNT  
ALLOWS FOR VARIOUS ANGLES  
WORKS WITH OR WITH OUT 3 OR 4  
WAY ROLLERS

in[mm]

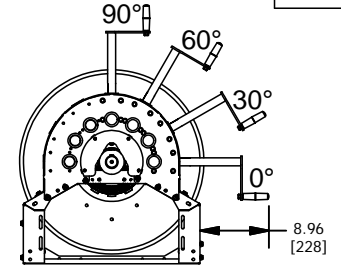
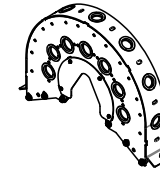

### BEVEL CRANK HANDLE HOLSTER

HOLSTER INCLUDES RETAINING  
PIN FOR AUXILIARY CRANKS &  
MOUNTS TO ANY BEVEL MOUNT  
BRACKET & DIRECTLY TO FRAME

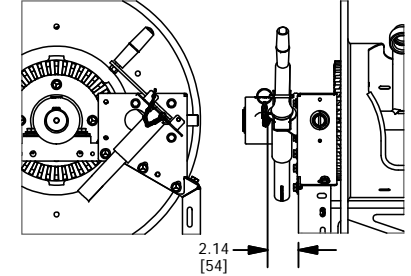
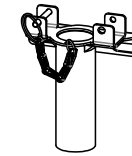

### GUARDING OPTIONS

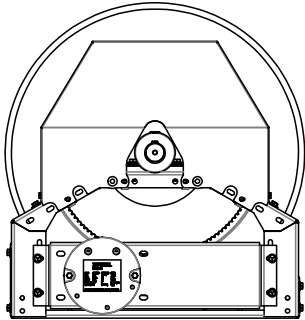

ABS FORMED OR METAL CHAIN &  
BEVEL GEAR GUARDS DEPENDING  
ON SPROCKET SIZE

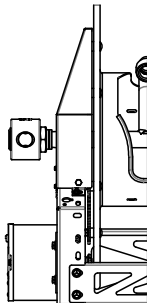

### 3-WAY PIN LOCK

(3 POSITION HEAVY DUTY PIN LOCK)

PATENT PENDING

¾" SOLID STEEL PIN  
LOCKING EVERY 20°  
EXTERNAL GREASE FITTING

#### 3 POSITIONS

- 1) LOCKED REEL
- 2) FREE SPIN
- 3) LEVER ACTIVATED REWIND  
(TRIGGERS ELECTRIC MOTOR REWIND)

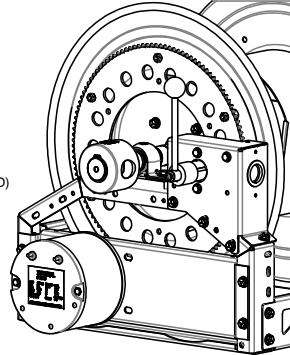
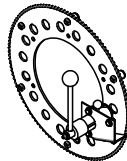

### BRAKE UPGRADES

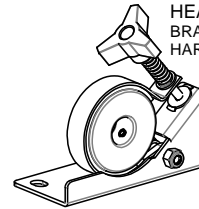

HEAVY DUTY BAND BRAKE  
BRAKE PAD LINED BAND  
HARDENED STEEL DRUM

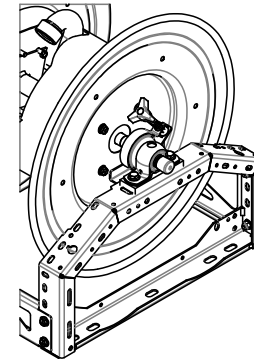

HEAVY DUTY  
BAND BRAKE

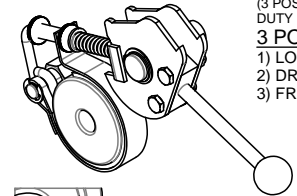

3-WAY BRAKE  
(3 POSITION HEAVY  
DUTY BAND BRAKE)  
3 POSITIONS  
1) LOCK REEL  
2) DRAG BRAKE  
3) FREE SPIN

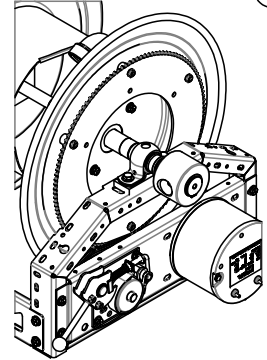

3-WAY BRAKE  
ON IDLER SHAFT

### CONTROL BOX

(NEMA 1 ENCLOSED ELECTRICAL BOX)

12VDC OR 24VDC  
CIRCUIT BREAKER  
MOTOR SOLENOID  
MOMENTARY SWITCH  
WIRE STRAIN RELIEFS

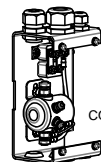

SHOWN WITH  
COVER REMOVED

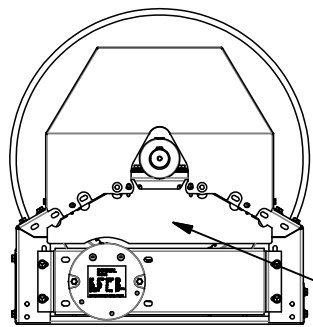
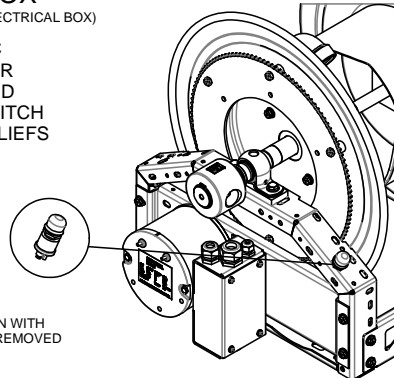

LOWER CHAIN GUARD COVERS  
ACCESS TO CHAIN FROM OUTSIDE  
AND INSIDE OF FRAME

## COXREELS

5865 S Ash Avenue Tempe, Az 85283  
1-800-COX-REEL www.coxreels.com

THIS DOCUMENT CONTAINS PROPRIETARY  
INFORMATION AND IS THE PROPERTY OF COXREELS,  
INC. THE COPYING, DISTRIBUTION AND UTILIZATION  
OF THIS DOCUMENT AS WELL AS COMMUNICATION  
OF ITS CONTENT TO OTHERS WITHOUT THE WRITTEN  
AUTHORIZATION OF COXREELS, INC., IS PROHIBITED.

TITLE: **1600 SERIES, OPTIONS &  
ACCESSORIES**

DWG. NO.:	1680-XX24	REV.	B
3RD ANGLE	INTERPERT PER ASME : Y14.5M-1994 DO NOT SCALE DWG.	SIZE: A	SHT:2 OF:2